

# Advanced Coupled Code Systems for Transient and Accident Analyses of European LWRs

Kiril Velkov and Yann Périn (GRS mbH)

## ABSTRACT

Most of the acceptance criteria are local values in the reactor core (thermal-hydraulic, neutron-kinetic or thermal-mechanic fuel pin parameters). The main goal of performing safety analysis is to check whether these criteria are met during a transient or an accident in a NPP. For this purpose GRS has developed a number of coupled thermal-hydraulics/neutron-kinetics (TH/NK) system codes which can solve the defined goal on assembly- or pin-by-pin level. Three types of coupling are applied depending on the utilized codes and application purposes: internal, external and parallel.

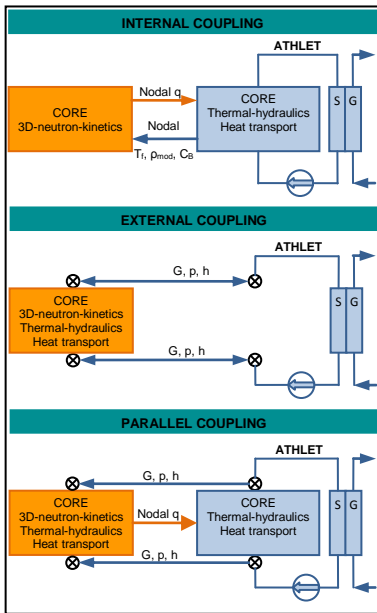

Types of coupling

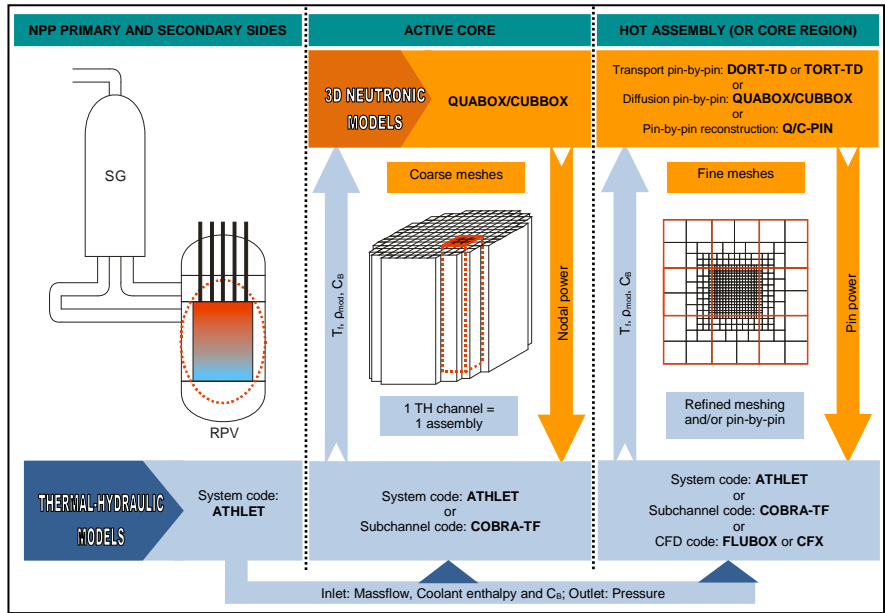

General approach for performing detailed NPP and core analysis

### ATHLET-QUABOX/CUBBOX

The backbone of the GRS strategy is based on the coupling of its thermal-hydraulic system code ATHLET with the nodal diffusion neutron-kinetic code QUABOX/CUBBOX. A methodology is developed for pseudo 3D TH description of the core with mapping schemes fitted to the 3D neutronics simulated active core. A large number of benchmarks has been very successfully solved with the coupled system code and many analyses have been performed for NPP with PWR, BWR and RBMK reactors.

Based on the universal ATHLET-interface, other neutronics codes have been coupled, e.g. the codes BIPR-VVER (RRC 'Kurchatov Institute', Russia), KIKO3D (KFKI, Hungary), DYN3D (FZD, Germany) and SADKO (RDIPE, Russia). These codes have been applied mainly for performing analyses of reactors with hexagonal fuel assembly geometry. The coupled code ATHLET-BIPR-VVER is widely used for performing not only safety analyses of the VVER-1000 and VVER-440 reactors on operation but also for design purposes for new reactor concepts.

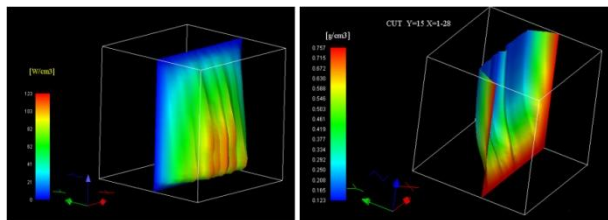

BWR axial power distributions (left) and coolant density distribution (right)

### ATHLET / DORT-TD and ATHLET / TORT-TD

The coupled system code ATHLET / TORT-TD is a next-generation simulation tool, featuring the 3D dynamic multi-group discrete ordinates ( $S_N$ ) and  $P_1$  scattering cross section expansion transport code TORT-TD for detailed pin-by-pin calculations.

### QUABOX-CUBBOX / COBRA-TF and TORT-TD / COBRA-TF

Using COBRA-TF sub-channel simulation capabilities, these coupled system codes were recently developed and are under validation for performing pin-by-pin analysis.

TH/TH coupling under development and testing:  
**ATHLET / COBRA-TF, ATHLET / FLUBOX** (GRS CFD code) and **ATHLET / CFX**.

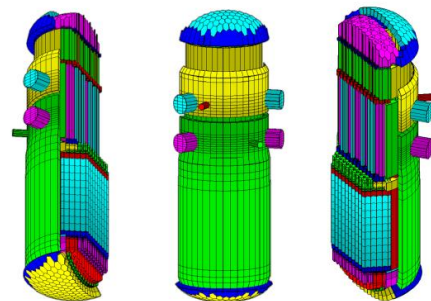

Detailed ATHLET nodalization of VVER-1000 reactor pressure vessel