Experiments on the Risk of Sump Plugging On French PWR

I. Vicena, V. Gubco, J. Batalik, J. Murani*

M. Davydov, O.I. Melikhov, V.N. Blinkov**

Y. Armand, JM. Mattei***

VUEZ, a. s. Levice, Sv. Michala 4, 934 80 Levice, Slovakia

*** EREC, 6 Benzymyannaya Electrogorsk, 142530 Moscow region, Russia*

**** IRSN, B.P. 17, 92262 Fontenay-aux-Roses, France*

Abstract: The "Institut de Radioprotection et de Sûreté Nucléaire" has decided to perform an experimental program of studies on the risk of sump plugging in a 900MWe pressurized water reactor (PWR). A general overview of the literature has been conducted between October 1999 and November 2000, ending by the definition of an approach methodology and the written of technical specifications. The problem identified gave rise to an European call for tenders leading to four contracts signed in november 2001. Three contracts are managed by VUEZ (Slovakia), the last by EREC (Russia). The methodology and the facilities devoted to these studies are presented in this paper, the preliminary results observed are also presented. The objectives for 2003 to finalize the program and the safety assessment are presented.

1. INTRODUCTION

Assessment of the operational characteristics of the filtration function used during the recirculation phase of safety injection system (RIS) and containment spray system (EAS) in the event of a break of the primary system in the containment began in October 1999. This was part of probabilistic safety assessment EPS2 conducted by the Institute. The CPY series, 900 MWe pressurized water reactors (30 reactors) were selected as they have a smaller filtration surface than other series.

The four filtering boxes are surrounded by a prefilter, known as the "large-debris barrier" (20 x 20 mm mesh). The filtering boxes (2.5 x 2.5 mm mesh) are sized to resist a differential pressure of 1.5 metre Ce. Any partial covering of their surface area (approximately 10 m²) causes flow modification and possibly air ingestion, as well as ingestion of small-sized debris. An anti-vortex floating cover is fitted inside the filtering boxes.

The thermal insulation on equipment and circuits is made of glass wool.

To estimate the risk involved, the following four points were studied:

- ⇒ an inventory of debris generated. This consists of the following types:
 - ⇒ glass wool thermal insulation fibers (spherical model: $L = 10.D$),
 - ⇒ paints (epoxy or polyurethane coatings studied in 1994 by the Institute),
 - ⇒ aluminum oxides,
 - ⇒ dusts present in the containment, in suspension or on the walls (theoretical estimation),
- ⇒ transfer of debris and structural modification of debris in the containment,
- ⇒ filtration efficiency and modification of sump hydraulics / air and debris ingestion,
- ⇒ operation of RIS and EAS circuit equipment with mud and air present.

The subjects giving rise to important questions have been collected and a corresponding full-scale experimental program has begun. It concerns:

- transfer of generated debris to the bottom of the containment, as it crosses the grating system and also under the action of chemical and thermal breakdown,
- settling and transport of generated debris at the bottom of the reactor building,
- the pressure drop value at the 4 filters of each suction inlet.

The following four points are currently under experimental investigation:

- ⇒ ELISA loop (VUEZ / SLOVAKIA): breakdown of fibrous debris so-called efflorescence (chemical action of water, effect of temperature),
- ⇒ IVANA loop (VUEZ / SLOVAKIA): grinding of fibrous debris on the grating system (mechanical action of falling water),
- ⇒ VITRA loop (EREC / RUSSIA): horizontal transfer speed of debris,
- ⇒ MANON loop (VUEZ / SLOVAKIA): pressure drop and air and debris ingestion at the sump filters.

The last item is under progress until December 2002, the others are now finished. The purpose of this paper is to present the different facilities and the preliminary results observed.

2. EFFLORESCENCE

2.1. OBJECTIVES AND REQUIREMENTS

The experimental program was carried out in the form of tests whose objective was to verify and quantify mechanical, chemical and thermal effects of working fluid (hot water containing 2000 ppm boron and treated with NaOH to pH 9) on defined insulation samples, namely:

- effects of the working fluid on leaching the binding agent from insulation samples,
- degradation of insulation as a result of fibers coming loose and washed out and its time dependence.

The test equipment had to meet the following requirements and criteria:

- to operate with hot water (up to 80°C) containing 2000 ppm of boron acid and having a pH value of 9 (NaOH) without any effect on the test equipment base material;
- to perform tests under thermal equilibrium conditions;
- to assure a controlled flow-rate of the working fluid, between 1 and 12 m³/h/m² (spray);
- to assure working fluid homogenization by agitation;
- to enable monitoring of insulation behavior during the tests and the quantification of insulation degradation under the mechanical, chemical and thermal effects of the working fluid;
- to meet the requirements imposed upon the measuring system and instrumentation.

2.2. TECHNICAL DESCRIPTION OF THE LOOP ELISA

The test equipment (see Figure below) was outlined as a compact assembly consisting of:

- test equipment box enclosing the test pool and its accessories,
- working fluid circulation system,
- instrumentation and control system, and
- auxiliary equipment.

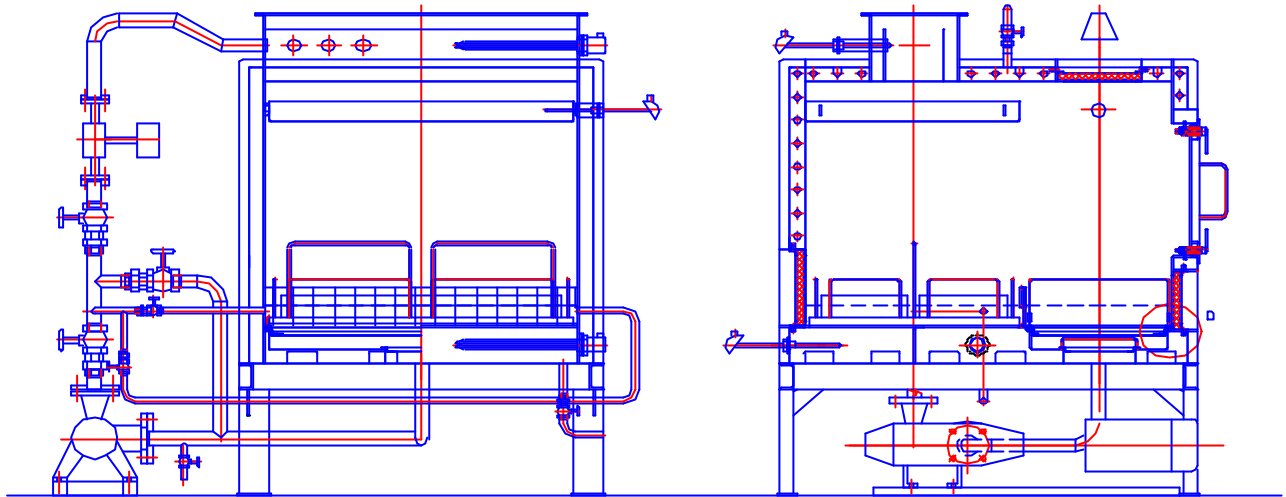

2.3. TESTS AND PROCEDURE OF EVALUATION

For the present experimental program, two types of thermal insulation were used:

⇒ Type 1 – glass wool with resin as binding agent – trademark TELISOL

sample dimensions 300 x 300 x 80 mm,

200 x 200 x 80 mm

⇒ Type 2 – glass wool – trademark BOURRE

sample dimensions 300 x 300 x 80 mm,

200 x 200 x 80 mm

Main test evaluation criteria were as follows:

- weight loss of tested samples depending on time,
- weight increase of insulation debris collected on individual filters depending on time,
- time behavior of the chemical composition of working fluid (pH, density, viscosity),
- optical analysis of samples taken,
- definition of fiber length distribution–fractional composition of the initial sample and individual samples taken from filters,
- identification of globular particles encountered in the given sample.

2.4. PRELIMINARY RESULTS

Two main phenomena have been observed:

⇒ A chemical effect appears when the temperature is more or equal to 40°C. 30% of the insulation mass is loosened after 96 hours,

⇒ When water used is not demineralized, a type a precipitate appears, which increases strongly the head loss observed (formation of particulates). It is noted that a containment is dirty enough to assume that the water is a "non demineralized source" during the recirculation phase, whatever the type of water initially stored.

3. GRINDING OF FIBROUS DEBRIS ON GRATINGS

3.1. OBJECTIVES AND REQUIREMENTS

The objectives are to verify and to quantify the kinetics of disintegration of thermal insulation under the mechanical effects of falling water and evaluate the character of insulation debris obtained after grinding.

3.2. TECHNICAL DESCRIPTION OF THE LOOP IVANA

To meet the objectives defined above, the test equipment shall meet the following requirements and criteria:

- to enable fall by gravity of water with ambient temperature on insulation samples from a height of ~ 4,6 m;
- to assure a controlled water flow-rate (between 50 and 1100 m³/h) with the required cross-sectional area of the discharge opening (0,3 and 0,9 m²);
- to enable the collection of ground and washed-out insulation debris on filters, filter removal and debris analysis during experimental testing;
- to satisfy the requirements imposed upon the measuring system and instrumentation.

3.3. TESTS AND PROCEDURE OF EVALUATION

The parameters are flow rates, sizes of thermal insulation debris and area of discharge.

Main test evaluation criteria will be as follows:

- weight loss of tested samples depending on time,
- weight increase of insulation debris collected on individual filters depending on time,
- weight increase of insulation debris collected on filters in fractional distribution depending on time,
- video-records of test processes, album of photos and insulation samples.

3.4. PRELIMINARY RESULTS

The tests performed proved a substantial impact of mechanical effects of flowing water on thermal insulation degradation leading the samples (55% of its mass) to be transformed in simple fibres. Water discharge during the tests was limited to its free flow without any pressure or temperature effects.

4. SETTLING AND TRANSPORTATION

4.1. OBJECTIVE AND REQUIREMENTS

The objective was to identify, from a statistical point of view, the settling and transportation velocities of various samples as a function of the fluid velocity. The samples (2 thermal insulations, concrete, paint and oxides) are sized from 50 µm to 10 cm. Additionally, it was required to observe the effects of the concentration of debris, at 1, 5 % and 10 % and on the corresponding velocities.

4.2. TECHNICAL DESCRIPTION OF THE LOOP VITRA

4.2.1. SETTLING

Several aquariums of different dimensions to study sedimentation of debris have been used. For example, the investigations of sample settling (sizes 1 – 10 mm) needed an aquarium with two video cameras (Figure below).

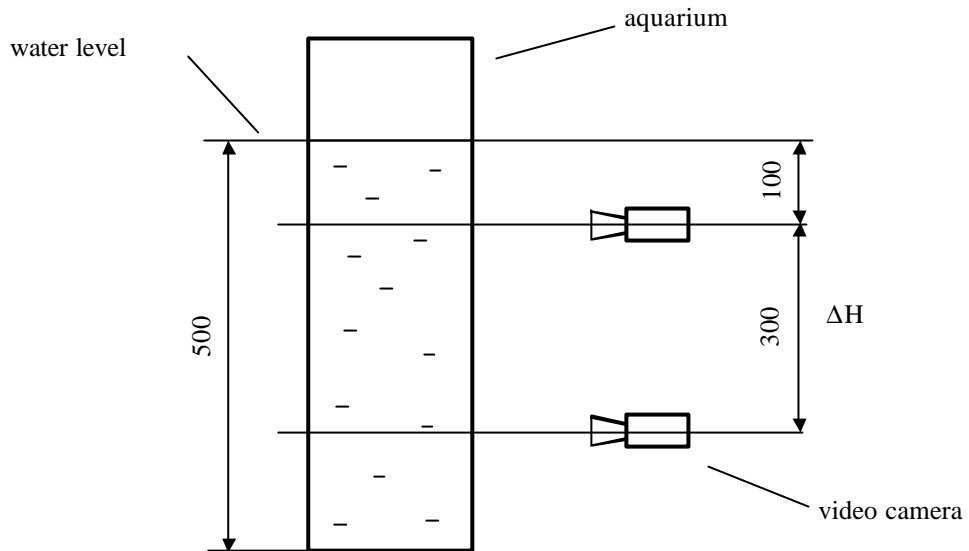

4.2.2. TRANSPORTATION

The loop VITRA is presented below. The mean velocity of the fluid is from 0 to 0,50 cm/s with a step less than 5 mm/s.

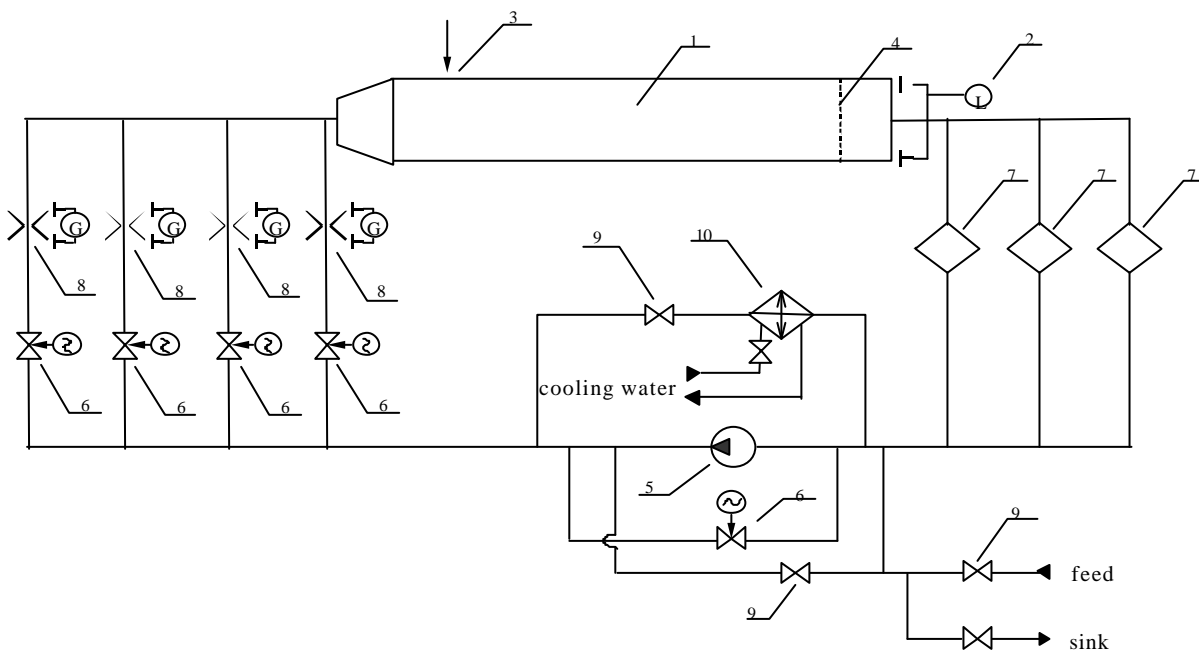

4.3. TESTS AND PROCEDURE OF EVALUATION

All measurements are made with cameras. Their synchronization was realized by special device (quadrator) and velocities were calculated after computer processing of images.

Special devices (optical fibers which have a few micrometers of diameters) are used to measure the fluid velocity in all points of importance. All other measurements are made according to standard means.

4.4. PRELIMINARY RESULTS

4.4.1. SETTLING

52 tests have been performed. A part of the results are presented below.

Material	Dimensions (mm)	Settling Velocity (cm/s)
Glass wool	100?100?80	8.3±1.5
Glass wool	50?50?50	7.6±0.3
Glass wool	20?20?20	7.0±0.6
Glass wool	10?10?10	4.7±0.3
Paint	30?30?0.2	3.1±0.5
Concrete	Ø0.3	3.5±0.2
Ferric oxide	Ø0.04	0.26±0.01

4.4.2. TRANSPORTATION

52 tests have been performed. A part of the results are presented below.

Material	Dimensions (mm)	Flow Velocity for 95% of samples begins to move (cm/s)
Glass wool	100?100?80	4.4±1.4
Glass wool	50?50?50	3.2±0.2
Glass wool	20?20?20	3.9±0.3
Glass wool	10?10?10	2.2±0.7
Paint	30?30?0.2	13.4±0.9
Concrete	Ø0.3	7.1±0.7
Ferric oxide	Ø0.04	6.0±0.5

5. HEAD LOSS AND INGESTION

5.1. OBJECTIVES AND REQUIREMENTS

In order to meet the objectives, the test equipment shall meet the following requirements:

- the test equipment shall be designed so to represent about ¼ of the full-size annular space with filter boxes and pre-filters in the scale 1:1;
- the test equipment shall meet the requirement for a maximum volume of working fluid circulating through the filter boxes – 1100 m³/h per one sump;
- the test equipment pump intake shall be separated from the annular space by means of a collecting tank;
- to define head loss of filter boxes and/or pre-filters under specified experimental conditions;
- to define the dependence of filter box and pre-filter head losses on the quantity of insulation fibres and particles and on the thickness of collected bed;
- to measure fluid flow velocity in selected locations;
- to measure air intake into the filter box discharge line;
- to define physical parameters of the bed consisting of insulation fibres and/or a mixture of insulation fibres and dust particles (porosity, length of fibres collected on filter surfaces and dimensions of particles);
- to define the quantity of fibres and particles that penetrated through the filter barrier;
- to measure the other parameters of the flowing fluid that are necessary to define experimental conditions (temperature, pH, viscosity, density).

5.2. TECHNICAL DESCRIPTION OF THE LOOP MANON

The figure below presents the loop MANON. The right part is the loop IVANA (pumps are used for both).

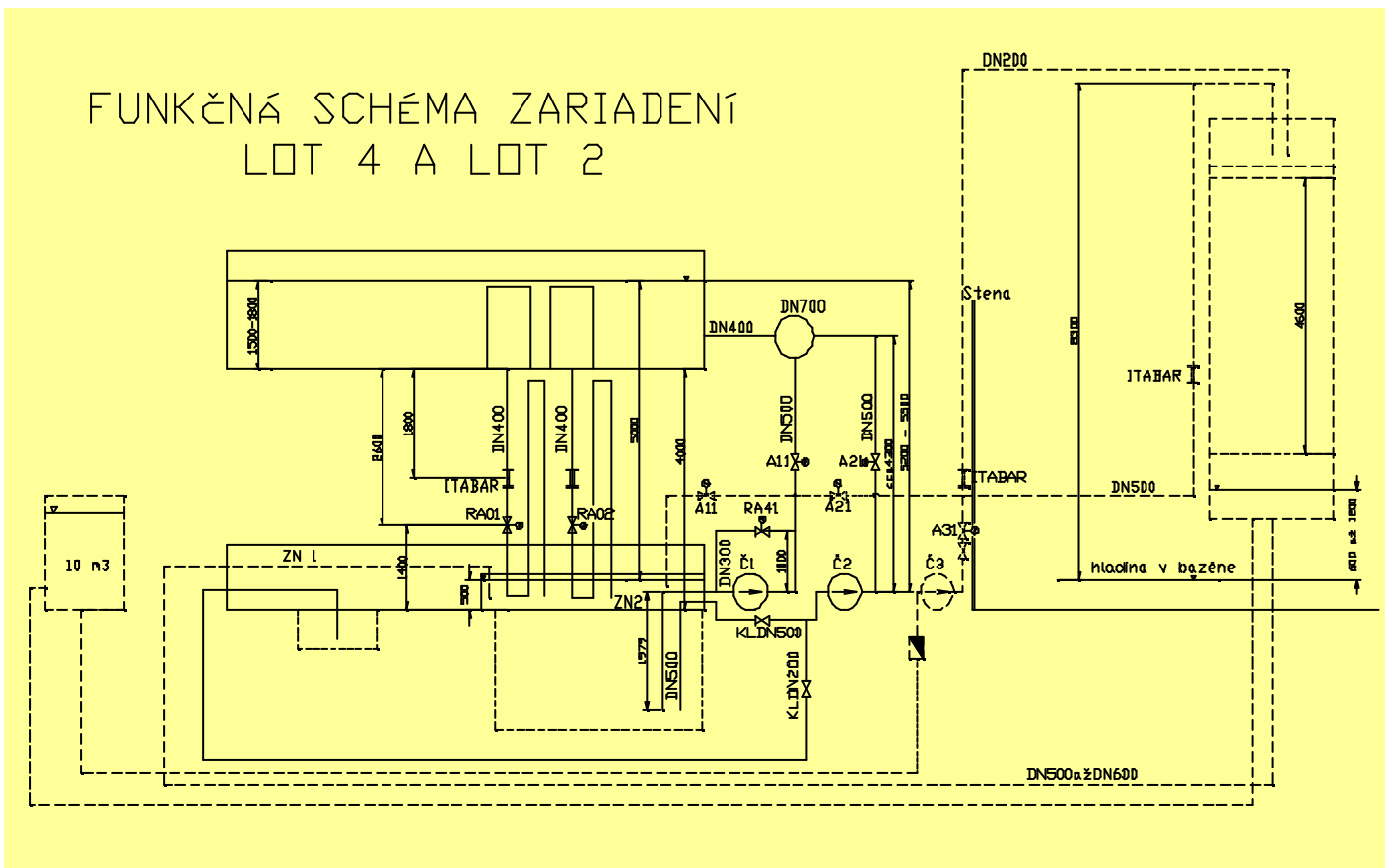

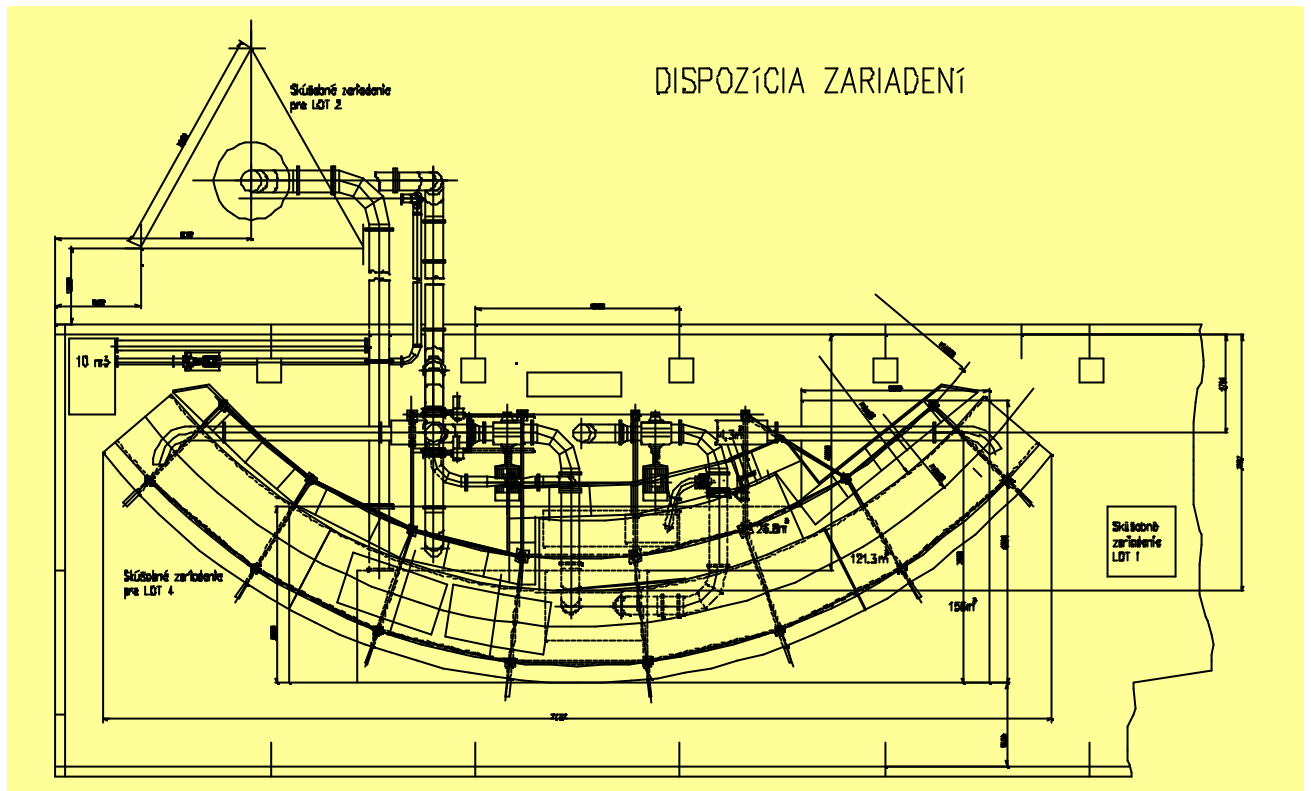

5.3. TESTS AND PROCEDURE OF EVALUATION

The criteria are the followings:

- weight of insulation and particles introduced into tank MN1,
- weight of bed removed from filter surfaces after test completion,
- operating parameters of the test equipment (flow-rate, temperature, level, pH, head loss),
- air intake,
- thickness of beds formed on filter surfaces,
- porosity of beds formed on filter surfaces,
- dimensional analysis of fibres and particles (fractional composition),
- collection of fibres and particles on filter surfaces and penetration through them,
- laboratory analysis of pH,
- composition and viscosity of test fluid,
- video recording and taking photographs,
- velocity field in tank MN1,
- level in tanks MN1 and MN2,
- head loss of filter boxes and pre-filters.

Two types of seeding have been used :

- pure fibers,
- fibers and particulates (between 85 and 150 μm).

5.4. PRELIMINARY RESULTS

The tests performed proved a substantial impact of insulation materials on the prefilters. In parallel, the level of water on the filters decreases. A large transient appears if the boxes are

uncovered and air gets into them. Moreover, the closing of one suction line leads to an increase of the speed of plugging of the neighboring filter. The quantity of particulates has a major impact on the head loss on the filters. In addition, a correlation is in progress to link the head loss obtained on the MANON loop with parameters such as pH or temperature. This correlation is established by use of the ELISA loop. The first results show a significant increase of the head loss due to these parameters.

6. CONCLUSION

A full-scale approach was chosen in order to answer to questions risen from a preliminary study. The following four points are currently under experimental investigation:

- ⇒ ELISA loop (VUEZ / SLOVAKIA): breakdown of fibrous debris (chemical action of water, effect of temperature),
- ⇒ IVANA loop (VUEZ / SLOVAKIA): grinding of fibrous debris on the grating system (mechanical action of falling water),
- ⇒ VITRA loop (EREC / RUSSIA): horizontal transfer speed of debris,
- ⇒ MANON loop (VUEZ / SLOVAKIA): pressure drop and air and debris ingestion at the sump filters.

The first information gathered is:

1. From 40°C, there is considerable degrading of thermal insulation fibers under the effect of water with a pH of 9, regardless of the flow rate considered. Temperature therefore has an extremely important influence on reaction kinetics. The degradation products are more often small-sized particles than fibers. If they agglomerate on the filters, the resulting pressure drops are much greater than those obtained with an equivalent quantity of fibers or clusters.

2. The degradation speeds of insulation materials under the effect of water falling from 4.6 m are relatively high and the insulation materials under the overflow are "pushed" and "cut up" within a few minutes, regardless of the flow rate (50% of the initial introduced insulation materials are cut up (mean value : 0,5mm)).

3. The approach used to characterize horizontal transfer of debris was based on a statistical study of the behavior of each type of debris involved, using appropriate video recordings. In the case of insulation materials, the fluid speed required to set 95% of debris in motion is $4 \text{ cm}\cdot\text{s}^{-1}$, and around $3 \text{ cm}\cdot\text{s}^{-1}$ for 50% of the debris. For paints, the fluid speed required to set 95% of debris in motion is $14 \text{ cm}\cdot\text{s}^{-1}$, and around $11 \text{ cm}\cdot\text{s}^{-1}$ for 50% of the debris.

4. Only the EAS system sumps are taken into account in the MANON loop. It emerges that for debris made up of a mixture of small debris and large debris (clusters of 20/30 mm), prefilter clogging produces a lowering of the water level around the filtering boxes. A large transient appears if the boxes are uncovered and air gets into them. The current tests will make it possible to define the quantity of insulation materials needed to cause EAS function failure. Moreover, the closing of one suction line leads to an increase of the speed of plugging of the neighbouring filter. In addition, a correlation is in progress to link the head loss obtained on the

MANON loop with the parameters as pH, quality of water, velocity or temperature. This correlation is established on the ELISA loop.

5. The quality of the water has an extremely important influence on reaction kinetics and consequently on the head loss of the filters.

The first information gathered will be validated and will have to be backed up by additional tests to be carried out at the end of 2002. A summary report on this study and test program will be published at the beginning of 2003.

As a consequence, it is required to pursue the investigations on the four testing loops using the already available data (progressive degradation of the debris, nature of the debris carried to the filters, ..) and proceeding with conditions as close as possible to an actual reactor (temperature profile, simulation of pump degradation due to its cavitation, ..).

Moreover, complementary investigations are needed to specify precisely the quantity of debris generated by the jet of water during an accident (small LOCA or large LOCA). In fact, at the present time, an assumption is made on the repartition of the debris generated in case of LOCA (20 % of fine fibers, 40 % of clusters and 40 % of large debris. Concerning a small LOCA, no data is available to estimate the insulation material quantity generated and also the amount of concrete particles destroyed. In this context, a solution is being sought in order to obtain better evaluation of the debris generated for different break sizes of loss-of-coolant accidents occurring in the PWR. This would enable us to obtain data that could be used in safety assessment.

The results of this programme will lead IRSN to debate the significant impact of the existing filters on the safety of the plants and to discuss with EDF the opportunity to improve the situation of the plants.